

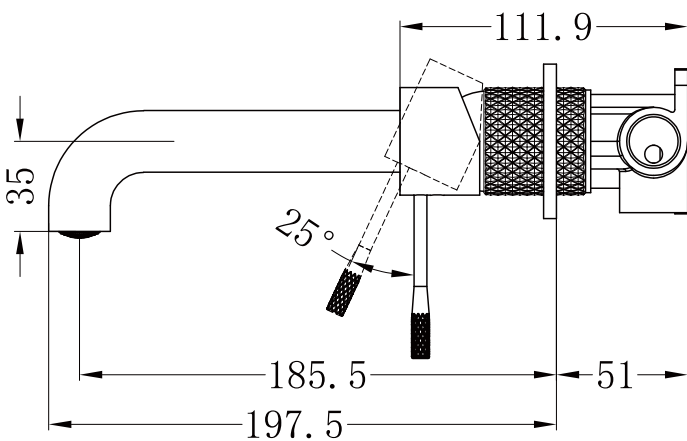

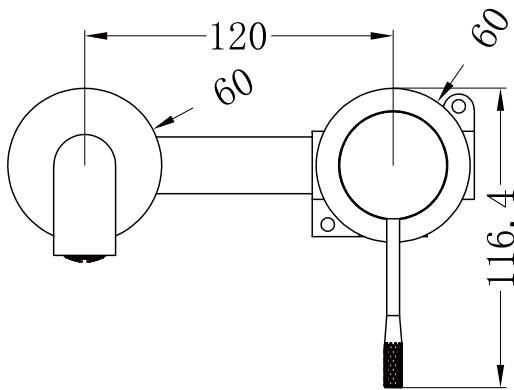

## Opal Wall Basin/Bath Mixer

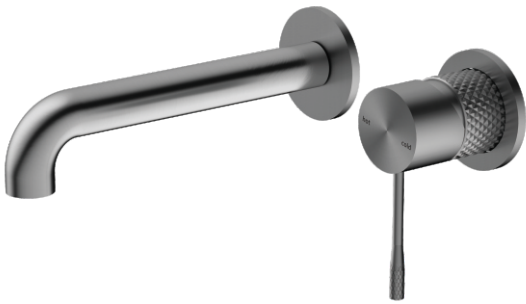

## SPECIFICATION

PRODUCT CODE	YSW2519-07B
WELS RATING	5Star 6L/Min
WATERMARK LICENSE	WM-060073
TEMPERATURE RATING	Min 1°C -Max 75°C
PRESSURE RATING	Min 150KPa-Max 500Kpa

## AVAILABLE FINISH

	GRAPHITE NR251907bGR		BRUSHED NICKEL NR251907bBN
	BRUSHED BRONZE NR251907bBZ		BRUSHED GOLD NR251907bBG

## MAINTENANCE AND CARE

All surfaces should be cleaned with mild liquid detergent or soap and water. Do not use cream cleaners or citrus based cleaning products, as they are abrasive. Use of unsuitable cleaning agents may damage the surface. Any damage caused in this way will not be covered by warranty.

## PACKING INCLUDES

- 1x mixer body
- 1x handle
- 1x spout
- 1x plate
- 1x accessories pouch
- 1x aerator driver
- 1x none restricted aerator



## Installation Instruction

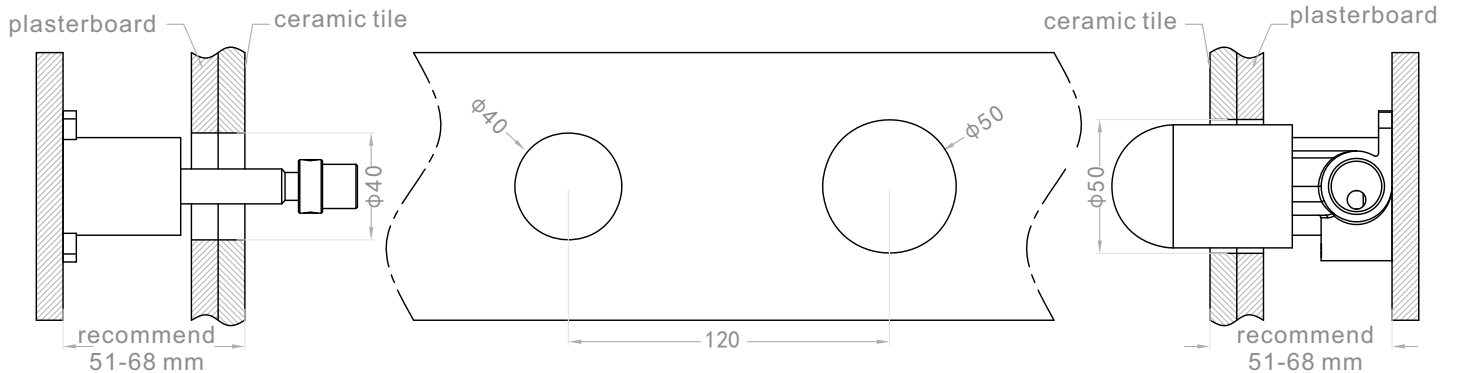

1. Fix body on noggin and ensure installation depth is 51-68mm from noggin to ceramic tile.
2. Connect cold water hose and hot water hose and conduct water pressure test for leakage.
3. Install plasterboard and ceramic tile after drilling a  $\phi 50$  and a  $\phi 40$  hole according to above picture.

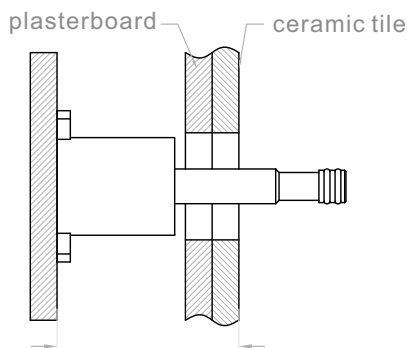

4. Remove the plastic sleeve, grub screw and water testing plug.

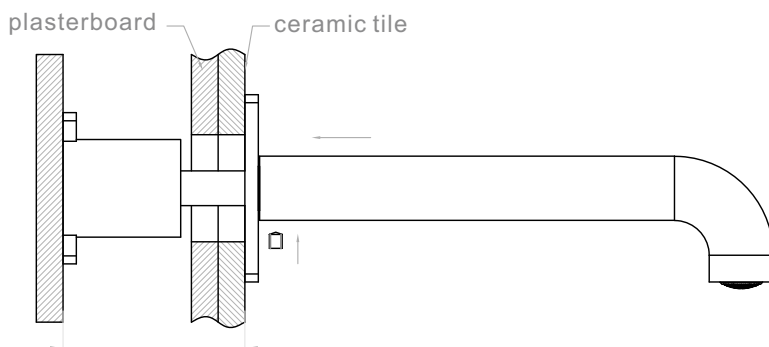
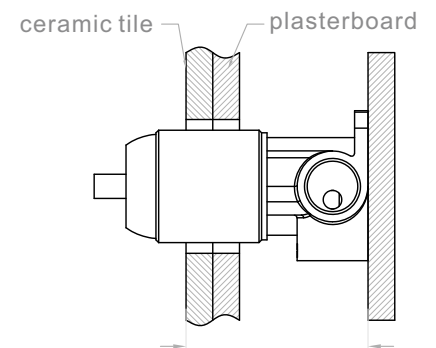

5. Install washer, plate, spout and handle.

